

ROTAPULS

All-round wheeled encoder for conveyor systems

Series

IR01



- Measuring wheel encoder
- Metric & US/imperial wheel sizes
- 1 channel output with anti-jitter & rollback functions
- Universal output circuit with quadrature signals (AB)
- Spring loaded arm with up to 30 mm deflection
- Conveyor speed control, cut-to-length & object positioning applications



IR01

ENVIRONMENTAL SPECIFICATIONS

Shock:	250 g, 6 ms acc. to CEI EN 60068-2-27
Vibrations:	10 g, 5-2000 Hz acc. to CEI EN 60068-2-6
Protection:	IP65
Operating temperature range:	-25°C +85°C (-13°F +185°F)
Storage temperature range:	-40°C +100°C (-40°F +212°F) (98% R.H. without condensation)

MECHANICAL SPECIFICATIONS

Dimensions:	see drawing
Wheel circumference:	Order code A = 317,6 mm (US/imperial) Order code B = 250.0 mm (metric)
Spring arm deflection:	30 mm
Shaft rotational speed:	2000 rpm
Starting torque at 20°C:	1 Ncm (typical)
Bearings life:	1 x 10 ⁹ rev. min.
Electrical connections:	M12 4 pin plug, M12 8 pin plug

ELECTRICAL SPECIFICATIONS

Resolution (PPR): <i>(other resolutions on request)</i>	25, 50, 100, 125, 250, 500, 1000, 1250, 2000, 2500, 5000
Accuracy:	±0,05 mm/turn (typ.)
Output signals:	A (with anti-jitter + roll-back functions) AB /AB (quadrature output)
Counting frequency:	50 kHz max.
Output circuits:	NPN o.c., Push-Pull, Universal
Power supply:	+10 +30Vdc, +5 +30Vdc
Consumption:	70 mA (typ.)
Output current (each channel):	40 mA max.
Protection:	against inversion of polarity and short-circuit
EMC:	electro-magnetic immunity, according to: EN 61000-4-2 EN 61000-4-4
Optoelectronic life:	100.000 hrs min.

MATERIALS

Fixing arm:	anodized aluminium, UNI EN AW-6082
Housing:	zamac die cast
Bearings:	ABEC 5
Shaft:	stainless steel, non-magnetic - UNI EN 4305

ACCESSORIES

EC-M12F8-LK-M8-5:	cordset 5m, M12 8 pin
EC-M12F8-LK-M8-10:	cordset 5m, M12 8 pin
E-M12F8:	mating conn. M12 8 pin
EC-M12PP-LK-PBS-5:	cordset 5m, M12 4 pin
EC-M12PP-LK-PBS-10:	cordset 10m, M12 4 pin
E-M12FC:	mating conn. M12 5 pin (1 pin unused)

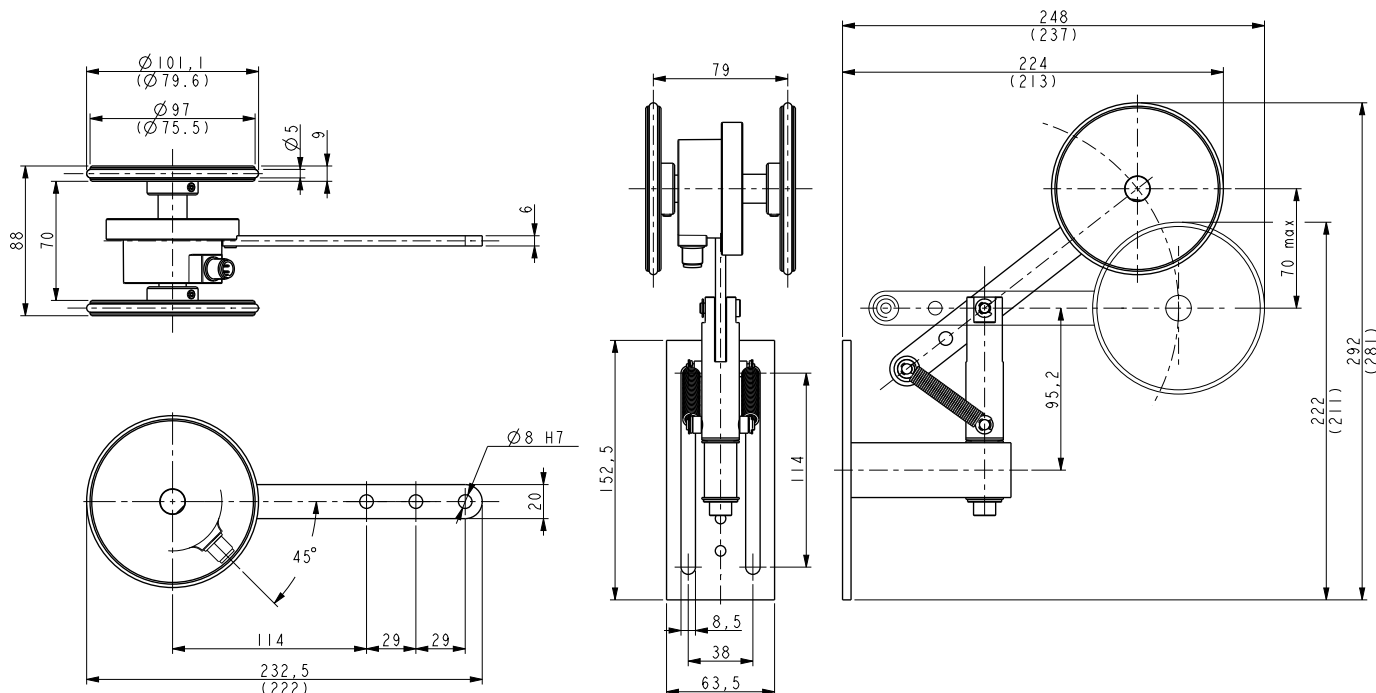

IR01

Order code

IR01	-	X a	-	XXX b	XXX c	X d	X e	/Sxxx f
------	---	--------	---	----------	----------	--------	--------	------------

<p>a OUTPUT CIRCUITS</p> <p>N = NPN o.c. Y = Push-Pull H = PP/LD universal circuit</p> <p>b RESOLUTION (PPR)</p> <p>250</p>	<p>c OUTPUT SIGNALS</p> <p>MNM = A with anti-jitter + rollback, M12 4 pin conn.</p> <p>d SUPPLY VOLTAGE</p> <p>2 = +10V ÷ +30V (N and Y output circuits) 4 = +5V ÷ +30V (H output circuit)</p>	<p>e WHEEL CIRCUMFERENCE</p> <p>A = wheel circumference 317,6 mm B = wheel circumference 250 mm</p> <p>f CUSTOM VERSION</p>
---	--	---

Order code

IR01	-	X a	-	XXX b	XXX c	X d	X e	/Sxxx f
------	---	--------	---	----------	----------	--------	--------	------------

<p>a OUTPUT CIRCUITS</p> <p>N = NPN o.c. Y = Push-Pull H = PP/LD universal circuit</p> <p>b RESOLUTION (PPR)</p> <p>See electrical specifications</p>	<p>c OUTPUT SIGNALS</p> <p>BCM = AB /AB, M12 8 pin conn.</p> <p>d SUPPLY VOLTAGE</p> <p>2 = +10V ÷ +30V (N and Y output circuits) 4 = +5V ÷ +30V (H output circuit)</p>	<p>e WHEEL CIRCUMFERENCE</p> <p>A = wheel circumference 317,6 mm B = wheel circumference 250 mm</p> <p>f CUSTOM VERSION</p>
---	---	---