

MDS

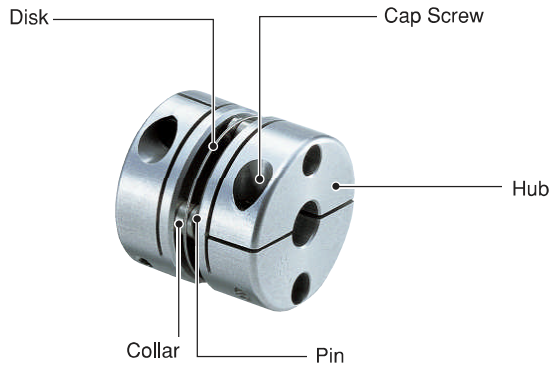

Configuration



Features

Merits

- High Torque, High Torsional Stiffness and Response
- Zero Backlash

- Disk type flexible coupling
- Compact coupling with short overall length
- Double stainless steel disks absorb angular misalignment and shaft end-play
Parallel misalignment is not absorbed
- Identical clockwise and counter-clockwise rotational characteristics
- Finished products featuring two different end bore diameters available in stock

Material & Finish

Hub	A2017, Anodized Aluminum Coating
Disk	SUS304
Pin	SUS303
Collar	SUS303
Cap Screw	SCM435, Black Oxide Coating*

* Stock screws can be replaced with stainless steel screws. Please take advantage of our stainless steel screw option. For more information please refer to page 16.

- For the ultimate high torque, high torsional stiffness, high response performance, take a look at the flexible disk coupling **XBS**.



XBS (P.42~P.45)

Application	
Servomotor	◎
Stepping Motor	◎
General-purpose Motor	—
Encoder	—
Features	
Zero Backlash	◎
High Torsional Stiffness	◎
High Torque	◎
Absorption of Misalignment	—
Vibration Absorption	—
Electrical Insulation	—
Corrosion Resistant (All Stainless Steel)	—

◎ : Excellent ● : Very Good

When Ordering

Specify product code and both bore diameters.

MDS-32C-10×12

Product Code

D₁

D₂



Technical Data

Thrust Reaction Force

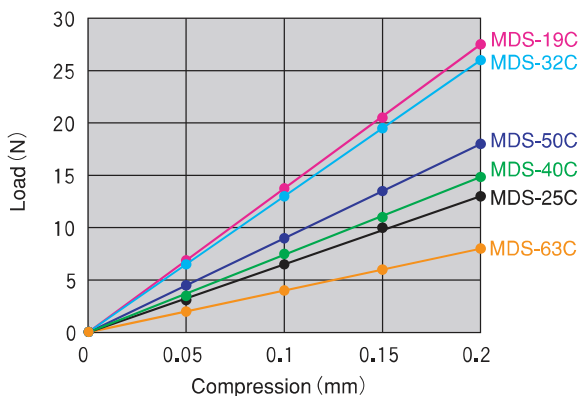

Changes in Static Torsional Stiffness Caused by Temperature

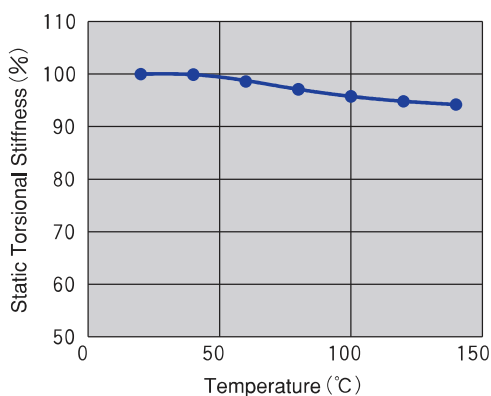

100% values represent product performance at 20°C. Because MDS experiences very little change in static torsional stiffness caused by temperature, the effect on response is minimal. However, please take into consideration that operating at high temperatures may lead to misalignment due to shaft distortion or elongation from thermal expansion.

Static Torsional Stiffness Comparisons

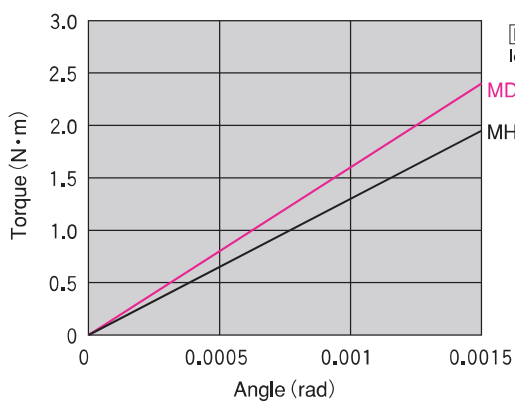

MDS has a high torsional stiffness and excellent response. Ideal for servomotors' high speed, high precision positioning.

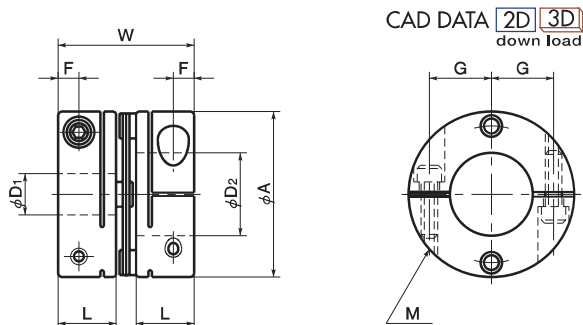

Dimensions

unit:mm

Product Code	A	L	W	F	G	M	Wrench Torque (N·m)
MDS-19C	19	8	20	2,5	6,5	M2	0,5
MDS-25C	25	10	24	3,5	9	M2,5	1
MDS-32C	32	12	29	4	11	M3	1,5
MDS-40C	40	14	33	5	15	M4	2,5
MDS-50C	50	18	42	6	18	M5	7
MDS-63C	63	20	46	7	24	M6	12

Product Code	Stock Bore Diameters																					
	D1 · D2																					
	4	5	6	6 ³⁵	7	8	9	10	11	12	14	15	16	17	18	19	20	22	24	25	28	30
MDS-19C	●	●	●		●	●																
MDS-25C			●	●		●	●															
MDS-32C						●	●	●	●	●												
MDS-40C						●		●	●	●	●	●	●	●	●	●						
MDS-50C										●	●	●	●	●	●	●	●	●	●	●	●	●
MDS-63C											●	●	●	●	●	●	●	●	●	●	●	●

- All products come with cap screws.
- Recommended tolerance on shaft diameters is h6 and h7.
- Bore and keyway modifications are available on request. Please take advantage of our bore modification services. For more information please refer to pages 17~19.

Specifications

Product Code	Max. Bore (mm)	Rated* Torque (N·m)	Max.* Torque (N·m)	Max. Rotational Frequency (min ⁻¹)	Moment** of Inertia (kg·m ²)	Static Torsional Stiffness (N·m/rad)	Errors of Angularity (°)	Errors of Shaft End-Play (mm)	Mass** (g)
MDS-19C	8	0.7	1.5	33000	6.3×10 ⁻⁷	280	0.7	±0.2	9
MDS-25C	12	1	2	25000	2.1×10 ⁻⁶	630	0.7	±0.2	19
MDS-32C	15	2.5	5	19000	7.2×10 ⁻⁶	1600	0.7	±0.2	41
MDS-40C	20	3.5	7	15000	1.3×10 ⁻⁵	2600	0.7	±0.2	68
MDS-50C	25	9	18	12000	6.1×10 ⁻⁵	3100	0.7	±0.2	140
MDS-63C	30	12.5	25	10000	1.7×10 ⁻⁴	4200	0.7	±0.2	250

* Adjustment of rated and maximum torque specifications for load fluctuations is not required. For more detailed information, please refer to For Better Drive on page 34.

** Based on the maximum shaft bores.